

## Controlling Methanol Contamination in Export Crude

Methanol (MeOH) contamination of crude oil is a growing concern in the oil and gas industry, as pipeline and refinery quality requirements become more restrictive. MeOH is used in multiple applications in the offshore oil and gas industry, including:

- Displacement of trees, well jumpers and well tubing (bullheading) for hydrate inhibition during shutdown operations.
- Equalization of pressure across subsea valves. Figure 1 shows an example of MeOH filled production tubing during a valve equalization procedure.

### The Problem with Methanol Contamination

For a typical well stream, the injected MeOH will partition into the water leaving a very small MeOH content in the oil. However, during the early life of a field, water cuts are typically low. The result is that much, or even all, of the injected MeOH remains in the oil stream, and is subsequently carried into the pipeline system transporting the crude to the refinery.

Export crude with a high MeOH content is considered problematic, due to the detrimental impact on water treatment processes in refineries. During the water treatment process, MeOH in the fluid is known to adversely impact treatment effectiveness in one of two ways<sup>1</sup>:

1. At low MeOH concentrations, the bacteria may begin to preferentially break down the MeOH as a food source, which temporarily reduces the effectiveness of the cleaning process.
2. At elevated MeOH concentrations, the MeOH can kill the bacteria, which significantly compromises the effectiveness of the process, until the population of bacteria is able to recover its previous equilibrium level.

Pipeline companies enter into contracts with refineries on the quality of the crude to be delivered. These agreed limits are then imposed on the crude producers via sales crude quality specifications, which include parameters such as basic sediment and water (BS&W), H<sub>2</sub>S content, and MeOH content. The largest consequence of MeOH contamination for the producers is the contractual penalties that may be incurred during the production of MeOH-contaminated crude.

### Controlling Methanol Contamination

Solving this contamination problem is a high priority topic for several projects in the Gulf of Mexico, due to their extremely low water cut at startup. There are three potential solutions applied to control MeOH contamination in crude:

1. Operational Approaches
2. Crude Washing
3. Eliminating the Use of MeOH

The most effective method to remediate the problem depends on the particular source and severity of the MeOH contamination.

### Operational Control

For one-time events, controlling MeOH content in export crude oil may be best achieved operationally. For platforms with multiple subsea tiebacks, the export oil will be commingled between producers before it is exported. Modeling of the transient event can be carried out to determine the MeOH concentration in the commingled export oil. The resulting concentration can subsequently be controlled by altering the well ramp-up rate for a given rate of MeOH delivery.

The most critical component for controlling MeOH content in the export crude is water content. By taking advantage of the resources available on the platform, the quality of the export crude can be improved. For example, mixing of the produced oil with the produced water from the other wells will reduce the MeOH content in the oil.

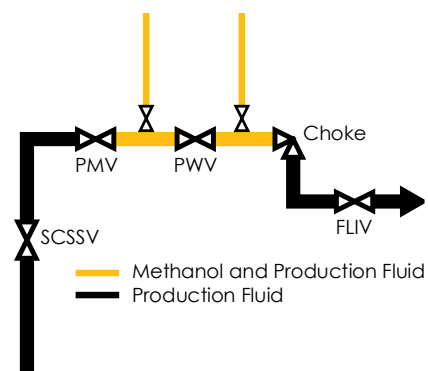

Figure 1: Valve Equalization Using Methanol

### Controlling Methanol Contamination In Export Crude

Operational Approach

Crude Washing

Eliminating Methanol Use

## Controlling Methanol Contamination in Export Crude

### Crude Washing

Crude washing can be effective in controlling MeOH contamination in a variety of circumstances.

In crude washing, additional water is added to the production stream to improve the MeOH partitioning behavior. Factors that affect crude washing feasibility and effectiveness include:

- Appropriate Mixing Times
- Number of Possible Injection Points
- Volume of Available Water

The benefit of crude washing is that no additional processing equipment is required to carry out the operation, beyond the piping necessary to carry water to the injection point along the processing stream. If the pressure in the processing stream at the selected injection location is higher than the wash-water injection pressure, additional pumps may be required to enable injection into the system.

Wash water can be sourced from multiple locations, including a water injection system, seawater lift pumps or, for small volume requirements, potable water systems. It is important, however, to ensure that the water is properly treated, and that all associated risks are considered. Wash water should ideally be deoxygenated and the system batch treated with a biocide to prevent corrosion in carbon steel systems. Additional steps may also be required to mitigate aspects such as scale formation and solids build-up, depending on the source of the wash water and the volume delivered.

Introducing water during restarts will aid in reducing MeOH content of the crude before it reaches the export pipeline, and will thus avoid contractual penalties for contaminated crude.

### Eliminating the Use of Methanol

An additional option to consider is the elimination of the use of MeOH for valve equalization by replacing it with an alternative fluid. This method may not be effective where MeOH is used as the primary means of hydrate control, and thus necessitates an in-depth analysis to prove the applicability of the alternative fluids.

Items to consider when selecting an alternative fluid to replace the utility function of MeOH include:

- Compatibility of new fluid with existing materials and chemicals in the system.
- Deliverability of the new fluid.
- Probability of additional processing difficulties introduced by this new fluid.

### Measuring Methanol Contamination

Since operational control and crude washing approaches do not completely eliminate the presence of MeOH, it is important that the level of contamination is carefully assessed. The difficulty and the reliability of predicting the level of MeOH

contamination are dependent on the nature of the contamination.

For continuous MeOH injection, the concentration of MeOH in the crude oil can be determined from relatively simple solubility calculations or heuristics. For more common transient events, the appearance of MeOH over time must be modeled, and concentration measured and calculated at various points throughout the duration of the excursion.

During startup, the MeOH that is injected subsea will flow with the production fluids, mixing slightly in the flowline and riser, depending on the nature of the produced fluids and the production rate. The concentration of MeOH in the produced crude oil can vary along the flowline, primarily due to the flowline bathymetry and fluid velocity. The concentration can be as high as 100% at specific locations, reaching topsides in the form of a slug.

The shape and duration of the MeOH excursion will vary based on ramp up rate, injected MeOH volume, and flowline bathymetry. The length of the MeOH slug, the duration of slug arrival topsides and the MeOH concentration in the contaminated crude during transient events can be calculated using typical flow assurance models under compositional tracking mode. GATE has developed a method using the simulation results in order to minimize and control the total MeOH concentration in the crude oil leaving the separator by controlling the well ramp up rate.

To model the processing and separation of MeOH from the export crude phase, process modeling software can be tuned to model the phase separation and keep track of the MeOH content in each of the phases throughout the production stream.

While modeling and analysis are excellent tools for measuring the magnitude of MeOH contamination or the relative effectiveness of MeOH control methods, it has been GATE's experience that the inherent conservatism of available models can lead to an over-design of the MeOH control method.

It is important that design of the MeOH control method be validated by sampling and lab analysis of the export crude by comparing the MeOH concentration of export oil during uncontrolled production to that of the MeOH content during controlled production. By measuring the baseline contamination level and the controlled contamination level, the MeOH control scheme can be adjusted to minimize operational oversight and expenses, while maintaining export crude MeOH content within acceptable limits.

### Conclusion

Regardless of the source of MeOH contamination, the key to controlling export crude contamination is either increasing available water in the production stream relative to MeOH, or operationally eliminating the need for MeOH during problematic operation events.

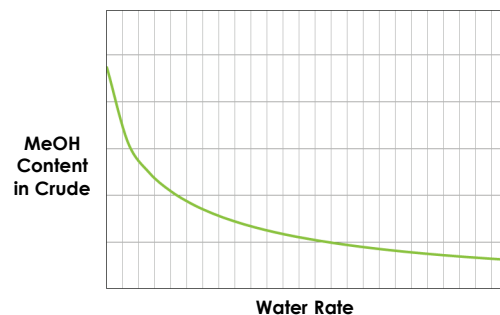

Figure 2: Effect of Crude Washing on Equalization Rate

### References

1. Crude Oil Contaminants and Adverse Chemical Components and Their Effects on Refinery Operations. Crude Oil Quality Group. May 27, 2004. Houston, Texas



From discovery to abandonment, upstream to downstream, GATE provides a systems approach to oil and gas facilities through our engineering, commissioning and marine services. Our goal is to provide solutions that allow our clients to make sure their projects work right the first time.

GATEKEEPERs are published for the benefit of our friends and clients. If you have any questions about this article, please contact us at [info@gateinc.com](mailto:info@gateinc.com) or **281.398.5781**

